



Interface Devices, Inc. Hydraulic Mini-Mule

INSTALLATION, OPERATION & MAINTENANCE MANUAL

**IMPORTANT! FILE THIS MANUAL IN A SAFE PLACE FOR FUTURE SERVICE & PARTS NEEDS
ALWAYS REFERENCE THE SERIAL NUMBER FOR SERVICE & PARTS REQUESTS**

Safety instructions specifically pertaining to this unit appear throughout this manual highlighted by the signal words ** Warning**** and ****Caution**** to denote different levels of hazard.**

Warning: denotes practices, which if not carefully followed, could result in property damage, **SERIOUS** personal injury and /or **DEATH**

Caution: denotes practices which if not carefully followed, could result in minor personal injury or damage to equipment.

Hydraulic Mini-Mule Serial Number: _____

STATEMENT OF WARRANTY

Interface Devices, Inc. (IDI) warrants its products to be free from defects in material and workmanship under normal use and service for a period of one (1) year from date of shipment. Any defect discovered after the warranty period has expired will be deemed to be outside the above coverage. No goods claimed to be under warranty shall be accepted for return unless authorized by IDI.

Upon discovery of a defect (other than freight damage) or a shortage of an item received in the original shipping container, the purchaser shall, within (10) calendar days, deliver notice of the defect or shortage. Damaged freight claims must be placed with the freight carrier and will not be honored by IDI. If after due investigation of a claim of defect or shortage is found valid, IDI, at its sole discretion, may discharge its entire obligation to the purchaser by either repair or replacement of the defective product or component and for shortages by furnishing a replacement of the missing quantity.

This express warrantee supersedes and is in lieu of all other remedies and warranties, including the implied warranties of merchantability and fitness for a particular purpose, and liability for negligence. IN NO EVENT SHALL IDI BE LIABLE FOR INCIDENTAL OR CONSEQUENTIAL LOSSES, EXPENSES OR DAMAGES INCLUDING DAMAGES FOR PERSONAL INJURY OR COMMERCIAL LOSS.

****WARNING****
Limitation of Liability

There is an inherent risk associated with pressurized hydraulic systems. Failure to follow the Manual’s instructions or other safety procedures increases the risk of serious personal injury or death. In addition to following the Mini-Mule safety precautions, remember to take appropriate safety measures with all components in the hydraulic system. In no event shall Interface Devices, Inc. be held liable for any property damage, injury or death in the event the Mini-Mule is NOT installed, operated or maintained in strict accordance with this manual and other published hydraulic service guidelines.

Table of Contents

1.0	General Description	1
2.0	Specifications & Features.....	2
2.1	Component Description.....	4
3.0	Safety Instructions	5
3.1	General Safety Precautions.....	6
3.2	Assembly:.....	6
4.0	Preparation for Operation	9
4.1	Operation.....	11
4.2	Disconnecting From the Aircraft.....	11
5.0	Maintenance	11
5.1	General.....	12
5.2	Storage	12
5.3	Rebuild.....	12
6.0	Troubleshooting:	13
7.0	Drawings	14

Copyright 2024. Interface Devices, Inc. All rights reserved. Information in this manual is subject to change without notice.

Comments or questions can be directed to:

Interface Devices, Inc.
230 Depot Rd.
Milford, CT 06460 USA

Ph: 203-878-4648
www.interfacedevices.com

INTERFACE DEVICES, INC.
- HYDRAULIC MINI - MULE -

1.0 General Description

Mini-Mule for “5606” Fluid

****WARNING****
Hydraulic Fluid

This Mini-Mule is designed for use with “5606” hydraulic fluid. Use of Skydrol fluid is not compatible with this Mini-Mule and will result in damage to the unit. Use of incompatible fluid could cause property damage, SERIOUS personal injury, and /or DEATH.

Features:

- No inlet air valve, air regulator or air lubricator required.
- Integrated circuit design. No external tubing or fittings.
- Maintains a constant pressure output with minimal air consumption.
- Polymeric seals and bearings for long life and high efficiency.
- Totally sparkless operation.
- Simple on/off air toggle pressurizes and depressurizes system.
- Compressed air input for operation or can be nitrogen powered for remote operation.
- 30:1 Pump ratio delivers 800-3300 psi hydraulic pressure with 80-110 psi inlet air pressure.
- No internal heat build-up
- Pre-tested with the specified hydraulic fluid.
- Can operate using aircraft reservoir or optional 2-gallon hydraulic system reservoir.
- Adaptable for multiple applications by varying output fitting configurations.

**** Caution ****

ALWAYS WEAR PROTECTIVE EQUIPMENT WHEN INSTALLING, OPERATING OR MAINTAINING THE MINI-MULE INCLUDING BUT NOT LIMITED TO SAFETY GLASSES, PROTECTIVE GLOVES, SHOES AND CLOTHING. FOLLOW ALL GUIDELINES ESTABLISHED IN THIS MANUAL AND THE MANUALS OF ALL OTHER EQUIPMENT USED IN CONJUNCTION WITH THE MULE INCLUDING THE AIRCRAFT MAINTENANCE MANUAL

INTERFACE DEVICES, INC.
- HYDRAULIC MINI - MULE -

2.0 Specifications & Features

Figure 1 – Pump

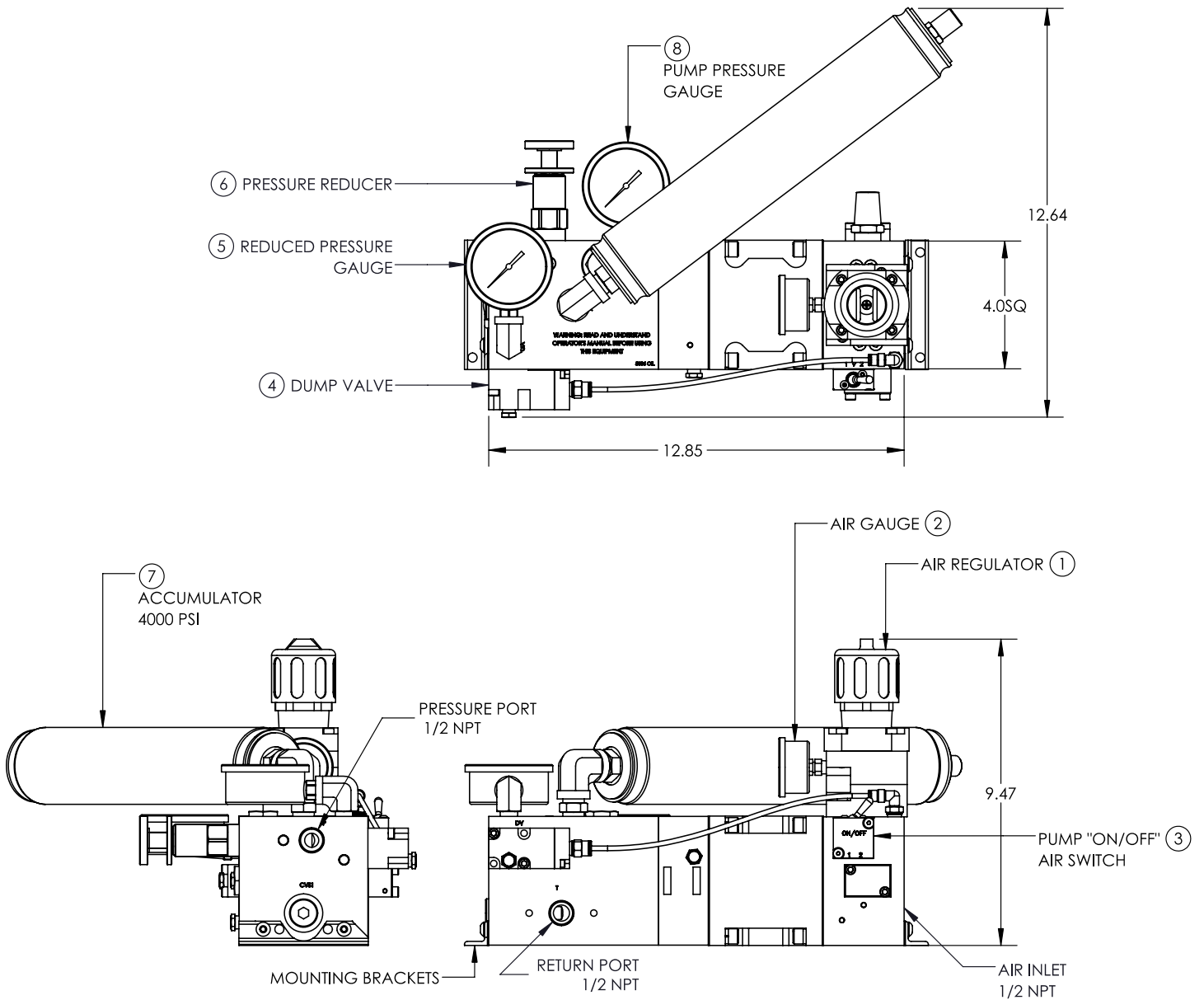

INTERFACE DEVICES, INC.
- HYDRAULIC MINI - MULE -

Figure 2 – Pump with 2-gallon Reservoir Option

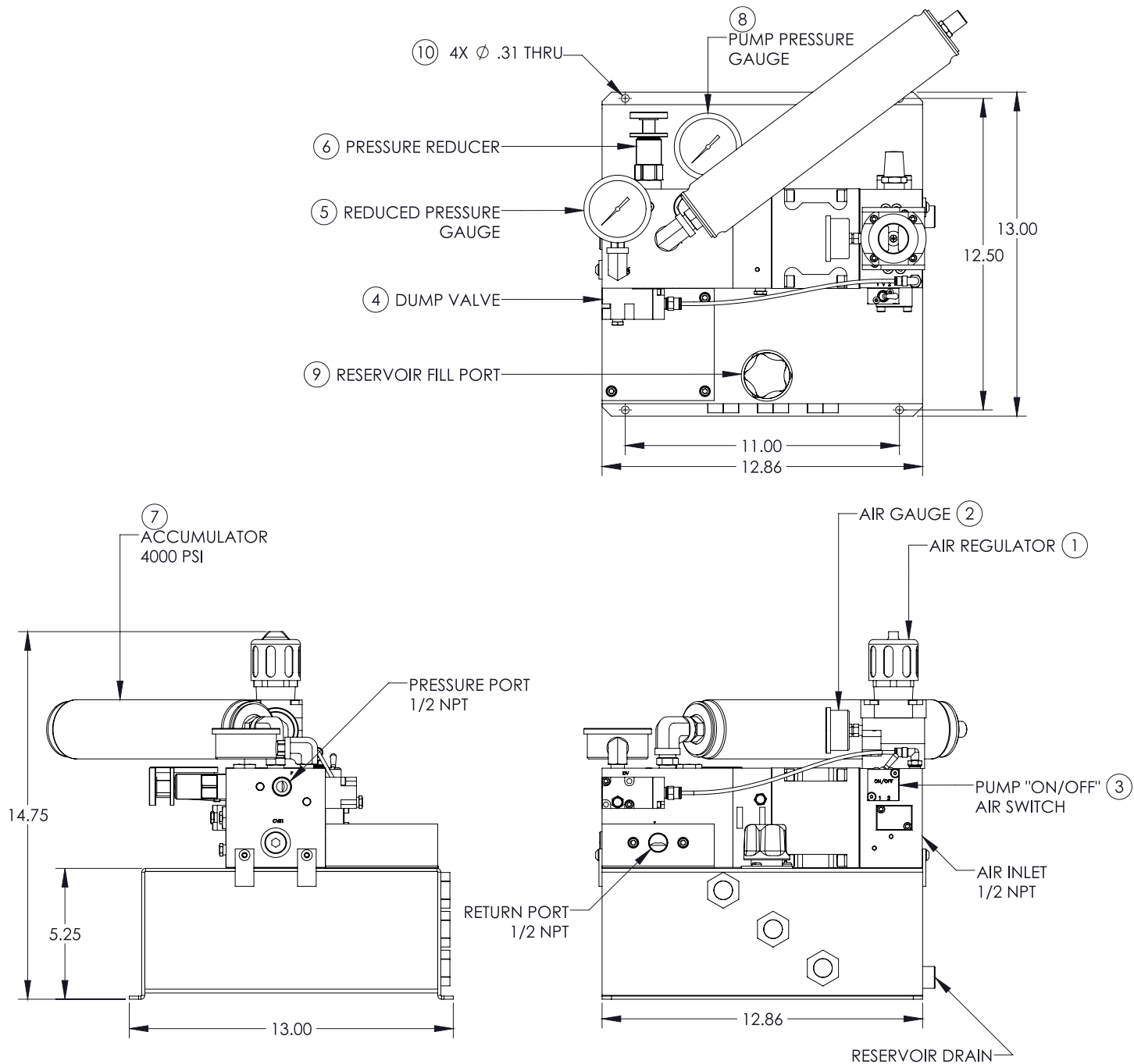

INTERFACE DEVICES, INC.
- HYDRAULIC MINI - MULE -

Item 1: Air Regulator

Item 2: Inlet Pressure Gauge

Item 3: Pump “ON/OFF” Switch (air operated)

Item 4: Dump Valve

Item 5: Reduced Pressure Gauge

Item 6: Pressure Reducing Valve

Item 7: Hydraulic Accumulator

Item 8: Pump Pressure Gauge

Item 9: Reservoir Filler/Breather

Item 10: Mounting Hole Locations

- “P” Pressure Port – ½ NPT
- Air Inlet – ½ NPT
- “T” Return Port – 1/2 NPT

2.1 Component Description

(Refer to Fig. 1. for component location.)

2.1.1 **Air Regulator:** Regulates the inlet supply pressure, as read on the inlet pressure gauge. Rotate the knob clockwise (IN) for higher output pressure. Rotate it counterclockwise (OUT) for lower pressures. Push the collar down to lock the Air Regulator.

**** Caution ****
DO NOT EXCEED 125 PSI INLET PRESSURE

2.1.2 **Inlet Pressure Gauge:** Reads the regulated shop supply pressure.

2.1.3 **“ON/OFF” Toggle Switch:** Provides the ability to turn the pump ON/OFF simultaneously actuating the Dump Valve CLOSED/OPEN

2.1.4 **Dump Valve:** Dumps system pressure when the pump is shut off.

2.1.5 **Reduced Pressure Gauge:** Indicates outlet pressure level as set by the Pressure Reducing Valve.

2.1.6 **Pressure Reducing Valve:** Controls the output pressure. Operator adjustable from 800 to 3300 psi. Rotate the valve clockwise (IN) for higher output pressure. Rotate it counterclockwise (OUT) for lower pressures. Lock the position of the valve by tightening the collar.

INTERFACE DEVICES, INC.
- HYDRAULIC MINI - MULE -

- 2.1.7 **Accumulator:** The accumulator pressure is typically precharged to 80% of the minimum system pressure. Allows for damping of pressure pulsations.
- 2.1.8 **Pump Pressure Gauge:** Indicates the internal pump pressure as dictated by the regulated air pressure.
- 2.1.9 **Reservoir Filler Breather:** Filler port for reservoir.
- 2.1.10 **Mounting holes:** Used for mounting the pump with ¼-20 fasteners.
- 2.1.11 **“P” Pressure Port:** System outlet port for the pressurized fluid. Pressure outlet at this port is indicated on the Output Pressure Gauge. This ½ NPT port is to be connected to the hydraulic supply of the aircraft with customer supplied hoses and fittings.
- 2.1.12 **“T” Return Port:** System fluid port. To be used to deliver fluid from the aircraft fluid reservoir to the Mini-Mule. This ½ NPT port is to be connected to the hydraulic reservoir of the aircraft with customer supplied hoses and fittings.
- 2.1.13 **Air Inlet:** Inlet supply pressure port. This ½ NPT port is to be connected to the compressed air supply with customer supplied hoses and fittings. ****DO NOT EXCEED 125 PSI****

Application: Designed for use by maintenance technicians for pressurizing and testing aircraft hydraulic systems and components. Pay special attention to fluid requirements as hydraulic fluids are not all compatible.

**** Caution ****

It is mandatory that this instruction manual be read, understood and followed by all persons operating this high-pressure hydraulic Mule.

3.0 Safety Instructions

- 3.0.1 General: Information presented in this manual and on various labels, tags and plates on the unit pertain to equipment design, installation, operation, maintenance and trouble shooting which should be read, understood and followed for safe and effective use of this equipment.

INTERFACE DEVICES, INC.
- HYDRAULIC MINI - MULE -

- 3.0.2 Safety: The operation, maintenance, and trouble shooting of this high pressure hydraulic Mini-Mule requires practices and procedures that ensure personal operator safety and the safety of others. Therefore, this equipment is to be operated and maintained only by qualified persons in accordance with this manual and all applicable local codes.
- 3.0.3 Training: Read through this entire manual prior to operation of this hydraulic Mule. All personnel using this Mule should understand and follow this manual and be properly trained. Contact Interface Devices for any specific questions about the installation, operation or maintenance of the Mini-Mule.

3.1 General Safety Precautions

- 3.1.1 Pressures: Fluids under pressure are a potential hazard in the form of stored energy. Accidents can occur when this energy is improperly handled. Be sure that all equipment used is compatible and designed to control the pressures encountered.
- 3.1.2 Hydraulic Fluid: Hydraulic Fluids can be hazardous to personal health and are potentially flammable. Take specific precautions for hydraulic fluid interaction, ie., gloves, safety glasses or face shield, etc. Do not use or store this Mule near open heat sources. Read and understand precautions in fluid Material Safety Data Sheet (MSDS) provided by the fluid supplier.

It is important to understand the dangers of operating around high pressure hydraulic systems.

**** Warning ****

High pressure hydraulic fluid leaks can be hazardous. It is not recommended to check for leaks with your bare hands. Be especially cautious of misting fluid leaks as they can cause shortness of breath, difficulty breathing, or respiratory damage.

3.2 Assembly:

- 3.2.1 Although the Hydraulic Mini-Mule is inspected prior to shipping, it could potentially be damaged during shipping. Therefore, it should be carefully unpacked and placed on a clean level surface for inspection. Please notify the shipping company of any damages as soon as possible.

INTERFACE DEVICES, INC.
- HYDRAULIC MINI - MULE -

Figure 3 – Pump to Reservoir Assembly

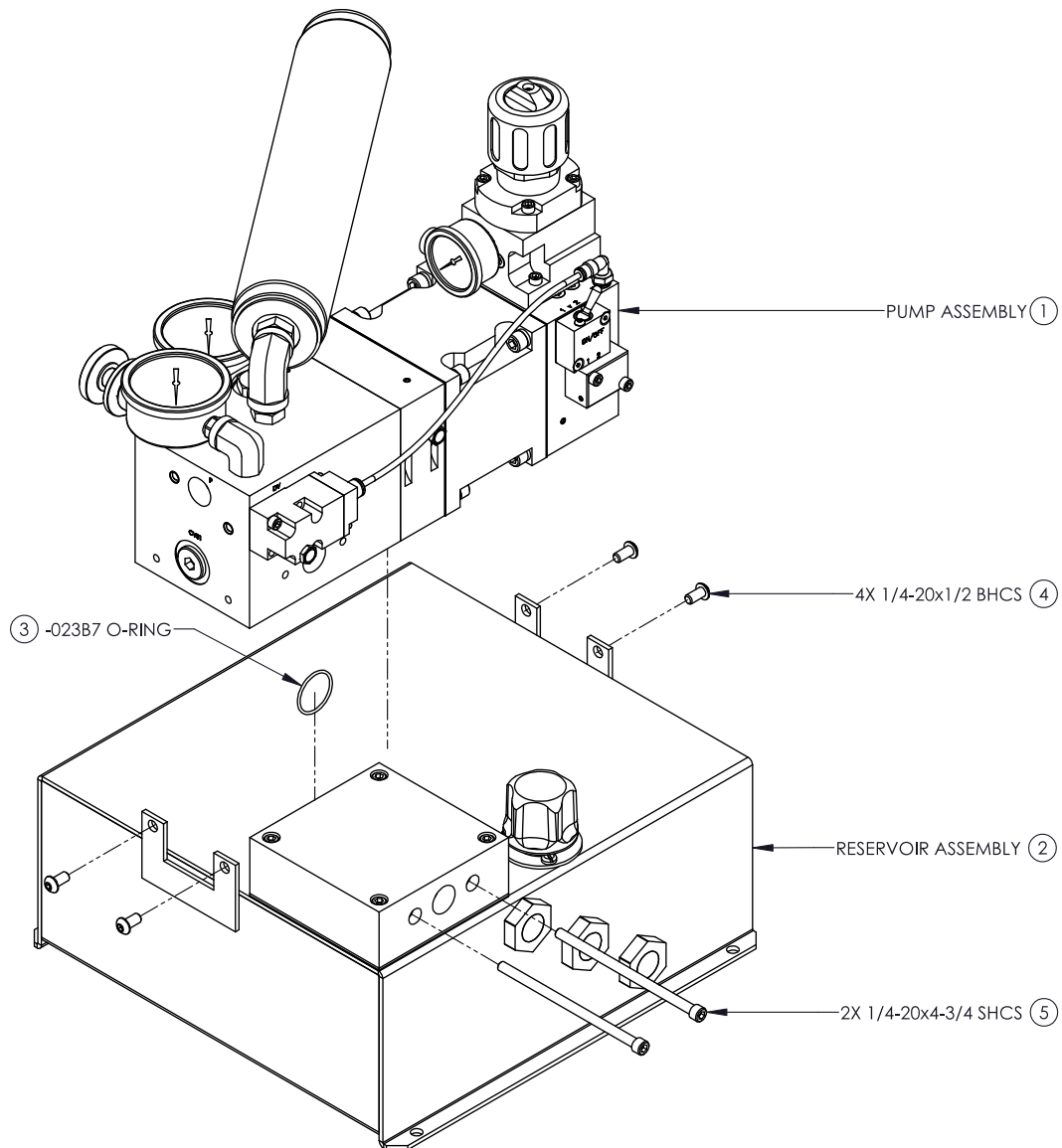

3.2.2 If reservoir option is included, the following steps are required to assemble the Mini-Mule:

1. Fit -023B7 O-ring into O-ring groove in Reservoir manifold.
2. Align Pump Assembly with Reservoir Assembly, making sure that O-ring is seated between manifold and Hydraulic Body.
3. Loosely fasten (4) BHCS and (2) SHCS.
4. Tighten all screws.

INTERFACE DEVICES, INC.
- HYDRAULIC MINI - MULE -

- 3.2.3 The Mini-Mule Reservoir is equipped with four (4) mounting holes for mounting with ¼-20 fasteners
- 3.2.4 Customer installed parts (Keep hydraulic components clean and contaminant free):
- a. High-pressure hose and fittings rated to a minimum of 4000 psi to connect to aircraft hydraulic supply.
 - b. Low-pressure return hose and fittings to connect to aircraft hydraulic reservoir
 - b. Air supply hose and fittings with shut-off valve rated for 125 psi minimum
 - c. 40 Micron inlet air filter rated to 125 psi at 40 SCFM

Dissimilar quick disconnect fittings are recommended for the two hydraulic hose assembly to ensure the Return line cannot be connected accidentally to the High-Pressure line. Clearly label each hose according with pressure rating.

COMPRESSED AIR COMPONENTS

- 3.2.5 A minimum supply hose inside diameter of ½ inch (12.7 mm) rated for a minimum of 125 psi. Hose assembly should have a ½ inch in-line shut-off valve.
- 3.2.6 Back the Air Regulator (CCW) all the way out.
- 3.2.7 Install a ½ inch, 40 micron minimum air filter as close as possible to the pump inlet with a ½ NPT pipe nipple.
- 3.2.8 With the shut-off valve in the “off” position, install the hose to the filter.

Note: Do not install a lubricator or external regulator.

CONNECTION TO MULE

- 3.2.9 Remove protective caps from “T” and “P” fittings.
- 3.2.10 Connect the hoses to the “T” (return) and “P” (pressure) ports. Tighten securely.
- 3.2.11 Install protective plugs in the free end of the hoses

Check all components for integrity. Carefully inspect all gauges, fittings, and connections for damage or leaks.

**** Warning ****

Always inspect unit before use. Damaged or contaminated or equipment should never be used.

INTERFACE DEVICES, INC.
- HYDRAULIC MINI - MULE -

4.0 Preparation for Operation

ACCUMULATOR NITROGEN PRECHARGE PROCEDURE:

**** Warning ****

Do not exceed 2500 PSI accumulator precharge. If the hydraulic system requires a higher accumulator precharge, contact Interface Devices for more information.

A dry nitrogen cylinder with a minimum of 3000 psi nitrogen available and an accumulator charge hose, gauge and charge valve assembly are required

- 4.0.1 Remove the cap from the accumulator's gas valve and connect the charge valve's adapter to it.
- 4.0.2 Open the accumulator's inlet valve.
- 4.0.3 SLOWLY open the valve on the nitrogen cylinder to allow nitrogen to flow into the accumulator.
- 4.0.4 Charge the accumulator to 80% of minimum operating pressure. When the required pressure is indicated on the charge gauge, close the cylinder gas valve.
- 4.0.5 Close the accumulator inlet valve.
- 4.0.6 SLOWLY loosen the charge valve assembly from the accumulator gas valve to allow trapped nitrogen to escape. Remove the assembly and install the gas valve cap to the accumulator inlet valve.

INITIAL START-UP, BLEEDING & PRESSURE SETTINGS:

- 4.0.7 Back-out the air regulator knob.
- 4.0.8 Turn-in the knurled knob of the pressure reducer valve (labeled "PR") 3 turns.
- 4.0.9 Remove both fittings from the aircraft end of the pressure and return hoses.
- 4.0.10 Connect the return hose from port "T" to the aircraft and tighten.
- 4.0.11 Connect the pressure hose from port "P" to the aircraft and leave it slightly loose for bleeding purpose.
- 4.0.12 Make sure the pump on/off air toggle switch is in the "off" position (toggle toward the air regulator).

INTERFACE DEVICES, INC.
- HYDRAULIC MINI - MULE -

- 4.0.13 Connect and turn on the air supply to the pump.
- 4.0.14 Switch the pump toggle switch to the "on" position (Toggle towards the hydraulic hose end of the pump).

**** Warning ****

Be careful of the fluid escaping the pressure line during the bleeding procedure. This fluid may be under pressure and can be emitted as a mist. Take the necessary precautions when torquing the pressure fitting after the air has escaped.

- 4.0.15 Slowly turn in the air regulator (CW) until the pump cycles slowly. Allow fluid to bleed through the loose pressure fitting until an air-free stream of oil is observed. Turn the toggle switch off and tighten the pressure fitting.
- 4.0.16 Turn the toggle switch on and adjust the air regulator until 2500 psi is noted on the Pump Pressure Gauge. (The pump will take several cycles to fill the Accumulator and then stop. The air pressure gauge will indicate approximately 85 PSI).
- 4.0.17 Re-adjust the knurled knob on the "PR" valve until the desired pressure is obtained on the Reduced Pressure Hydraulic Gauge.
- 4.0.18 Turn off the pump with the toggle switch. The pump will stop running and the hydraulic pressure will go to zero (the Dump Valve will open)

Your Hydraulic Mini-Mule is now ready for operation.

INTERFACE DEVICES, INC.
- HYDRAULIC MINI - MULE -

****Caution****

It is mandatory that the aircraft maintenance manual be read, understood and followed by all persons operating this high-pressure hydraulic Mule. System damage can occur if proper procedures are not followed.

4.1 Operation

- 4.1.1 Connect the pressure (“P”) and return (“T”) fittings to the aircraft or component and bleed the pump as described in section 4.0
- 4.1.2 Turn the Hydraulic Mule “on/off” switch to on.
- 4.1.3 Monitor the system hydraulic pressure on the pressure gauges of both the Mule and the aircraft. Ensure procedures and pressures comply with the aircraft maintenance manual.
- 4.1.4 Adjust the system pressure on the hydraulic Mule as required using the Pressure Reducing Valve.

4.2 Disconnecting From the Aircraft

- 4.2.1 Turn the Hydraulic Mule “on/off” switch to off.
- 4.2.2 Wait until the pressure dump valve has eliminated the residual system pressure. Ensure that both the aircraft indications and pump hydraulic pressure gauge are at 0 psi.
- 4.2.3 Disconnect the hydraulic hoses from the aircraft. Cap both hoses to prevent contamination.

5.0 Maintenance

**** Warning ****

Maintenance should be undertaken by qualified personnel only.

The operation, maintenance and troubleshooting of this high pressure hydraulic Mini-Mule requires practices and procedures that ensure personal operator safety and the safety of others. Therefore, this equipment is to be operated and maintained only by qualified persons in accordance with this manual and all applicable codes.

INTERFACE DEVICES, INC.
- HYDRAULIC MINI - MULE -

5.1 General

- 5.1.1 All maintenance performed on this Mini-Mule shall be conducted in accordance with all applicable codes governing the handling, operation, installation and trouble shooting for hydraulic operations. Maintenance is to only be done by qualified persons.
- 5.1.2 All maintenance personnel must be familiar with the cautions and warnings associated with high pressure hydraulic systems as outlined in sections 3.1 and 3.2 of this manual prior to performing any maintenance on this unit.
- 5.1.3 The pressure gauges on this unit should be inspected and calibrated annually to $\pm 3 \frac{2}{3} \%$ of span (ASME B40.1 Grade B), to maintain and ensure accuracy. Consult your own companies quality control guidelines for more specific requirements.
- 5.1.4 Air Spool Lubrication. **The only preventative maintenance task for the pump is to re-grease the air spool assembly every 6 months regardless of usage rate. Lithium based waterproof grease should be used for this task. Refer to assembly drawing in Section 7.0 of this manual when performing this task.**

5.2 Storage

- 5.2.1 Store the unit in a clean, dry, climate controlled and secure area when not in use.
- 5.2.2 Be sure all hoses are capped and the unit is covered with lint free material.

5.3 Rebuild

- 5.3.1 The Mini-Mule should be regularly inspected especially after periods of non-use. If the unit may have been compromised with suspect components or sub optimal operational or maintenance practices it can be returned to the manufacturer for a complete inspection, cleaning and rebuild service.

5.4 Seal Kits

- 5.4.1 Seal Kits can be purchased from the manufacturer using the following part numbers:
- 13457 – Pump Seal Kit (BUNA)
 - 13459 – Reservoir Seal Kit (BUNA)

INTERFACE DEVICES, INC.
- HYDRAULIC MINI - MULE -

6.0 Troubleshooting:

**** Warning ****

Troubleshooting should be undertaken by qualified personnel only.

Symptom	Probable Cause	Remedy
Pump will not cycle (No hydraulic pressure.)	No air supply to pump Pump regulator set too low Four-way air reciprocating valve spool stuck at mid position	Look for and fix Increase setting Disconnect/ reconnect air supply (resets air spool to end position) If spool still sticks, manually push spool to far end with probe through hole in “spool stop cap”. If stuck or requires excessive force, disassemble air valve assembly. Inspect for contamination or mechanical bind. Repair or replace, lubricate seals with lithium-based grease
Pump makes one cycle then stops	Faulty “2-way air Valve” (Broken, leaks or contaminated)	Repair or replace
Pump cycles constantly when Dead Headed	External leak at pump or down stream high pressure circuit Contaminated or stuck open check valve cartridge Internal leak in pump	Look for and correct Clean or replace Check all dynamic and static seals and gaskets

For further assistance, call Interface Devices, at 203-878-4648.

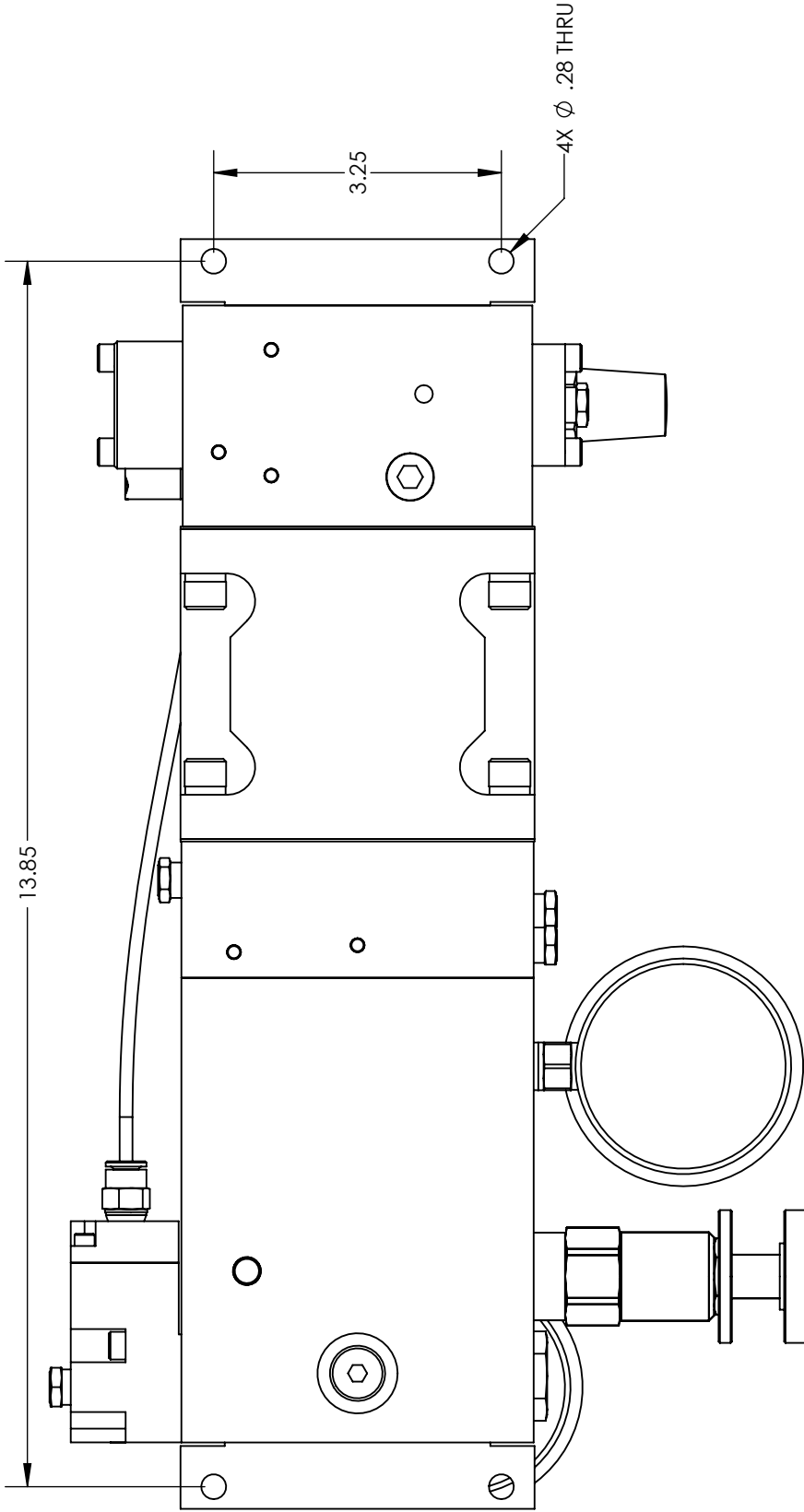

		INTERFACE DEVICES, INC. 230 DEPOT ROAD MILFORD, CT 06460	
SCALE: 1:2	TITLE: STANDALONE PUMP, MOUNTING FEATURES		
DWN BY: NPI	REF:		
DATE: 1/22/2024	SHT:		
DWG NO:	REV: -		

1

2

B

A

B

A

1

2

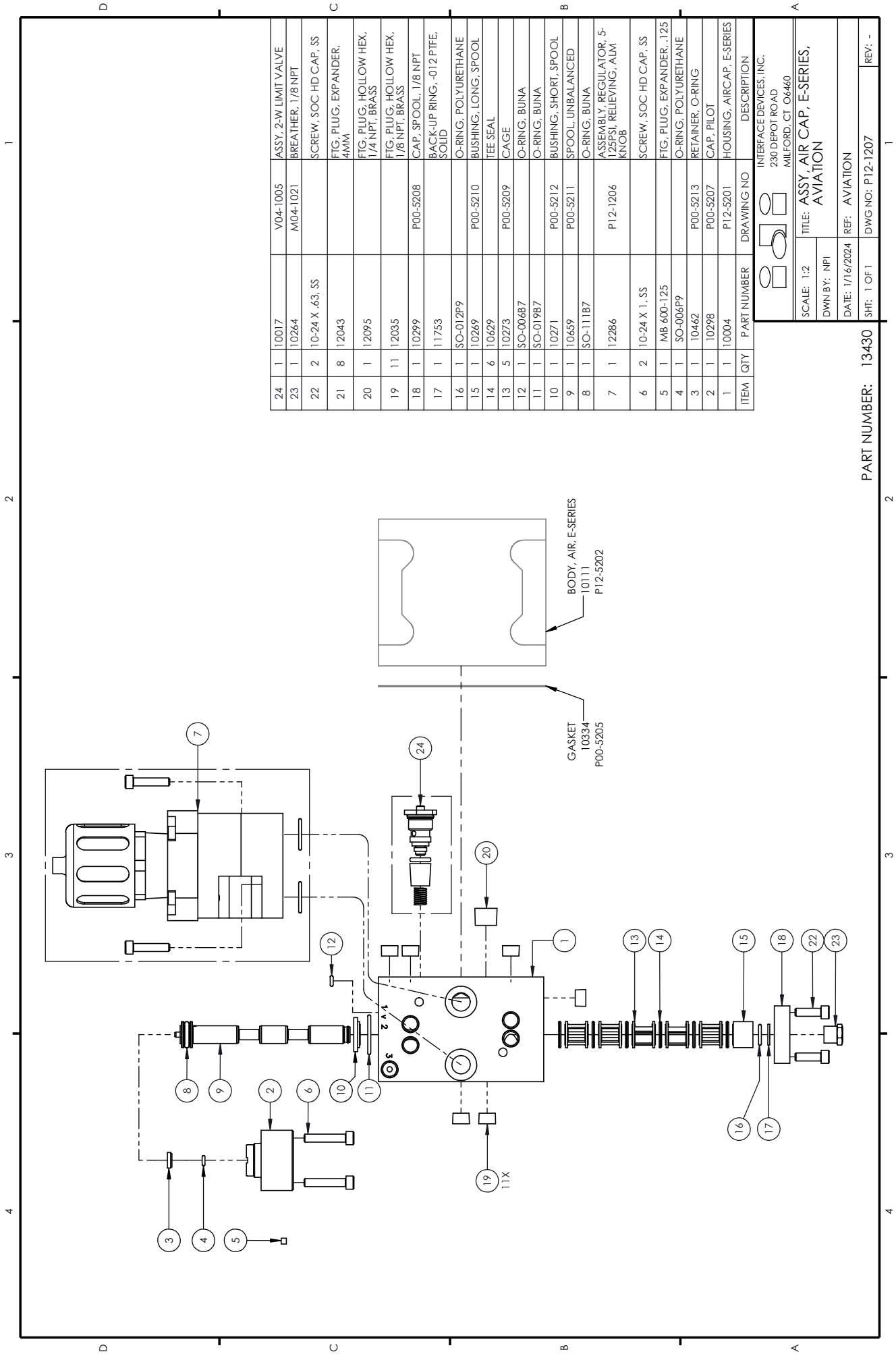

ITEM	QTY	PART NUMBER	DRAWING NO	DESCRIPTION
24	1	10017	V04-1005	ASSY, 2-W LIMIT VALVE
23	1	10264	M04-1021	BREATHER, 1/8 NPT
22	2	10-24 X .63, SS		SCREW, SOC HD CAP, SS
21	8	12043		FTG. PLUG, EXPANDER, 4MM
20	1	12095		FTG. PLUG, HOLLOW HEX, 1/4 NPT, BRASS
19	11	12035		FTG. PLUG, HOLLOW HEX, 1/8 NPT, BRASS
18	1	10299	P00-5208	CAP, SPOOL, 1/8 NPT
17	1	11753		BACK-UP RING, -012 PTFE, SOLID
16	1	SO-012P9		O-RING, POLYURETHANE
15	1	10269	P00-5210	BUSHING, LONG, SPOOL
14	6	10429		TEE SEAL
13	5	10273	P00-5209	CAGE
12	1	SO-00687		O-RING, BUNA
11	1	SO-019B7		O-RING, BUNA
10	1	10271	P00-5212	BUSHING, SHORT, SPOOL
9	1	10659	P00-5211	SPOOL, UNBALANCED
8	1	SO-111B7		O-RING, BUNA
7	1	12286	P12-1206	ASSEMBLY, REGULATOR, 5-125PSI, RELIEVING, ALUM KNOB
6	2	10-24 X 1, SS		SCREW, SOC HD CAP, SS
5	1	MB 600-125		FTG. PLUG, EXPANDER, 125
4	1	SO-006P9		O-RING, POLYURETHANE
3	1	10462	P00-5213	RETAINER, O-RING
2	1	10298	P00-5207	CAP, PILOT
1	1	10004	P12-5201	HOUSING, AIRCAP, E-SERIES

INTERFACE DEVICES, INC.
 230 DEPOT ROAD
 MILFORD, CT 06460

SCALE: 1:2
 DWN BY: NPI
 DATE: 1/16/2024
 SHEET: 1 OF 1

TITLE: ASSY, AIR CAP, E-SERIES, AVIATION
 REF: AVIATION
 DWG NO: P12-1207
 REV: -

PART NUMBER: 13430

1

2

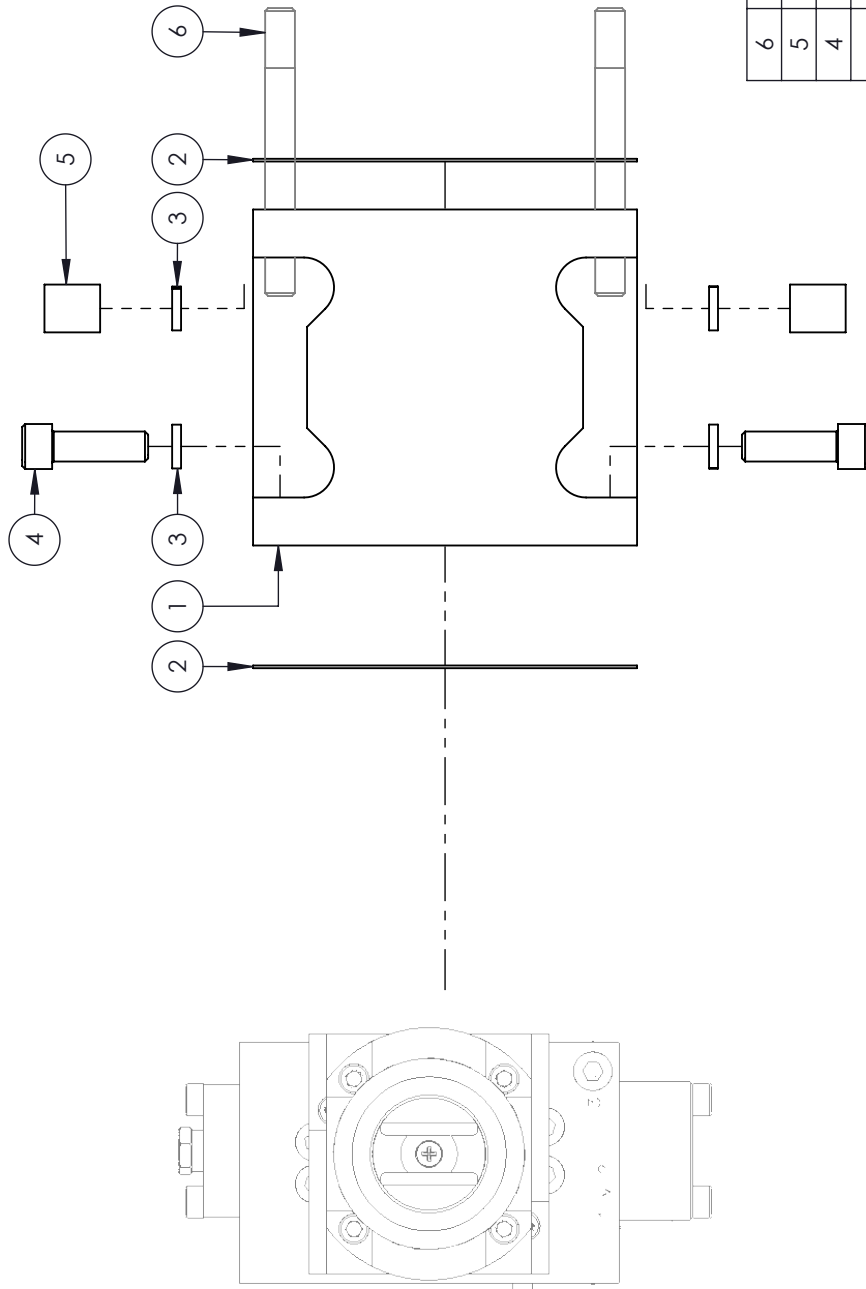

NOTES:
 1. ALL FASTENERS TO BE SS.

6	4	13470	STUD, 5/16-18 X 3.00, SS
5	4	12039	NUT, ALLEN, 5/16-18 SS
4	4	5/16-18 X 1.00, SS	SCREW, SOC HD CAP, SS
3	8	12271	LOCKWASHER, HI COLLAR, 5/16, SS
2	2	10334	GASKET, AIR BODY
1	1	10111	BODY, AIR, E-SERIES
ITEM	QTY	PART NUMBER	DESCRIPTION



INTERFACE DEVICES, INC.
 230 DEPOT ROAD
 MILFORD, CT 06460

SCALE: 1:2	TITLE: ASSEMBLY, AIR BODY, E-SERIES, MINI-MULE
DWN BY: NPI	
DATE: 3/11/2024	REF: MINI-MULE
SHT: 1 OF 1	DWG NO: P12-1208
	REV: -

PART NUMBER: 13471

B

A

B

A

1

2

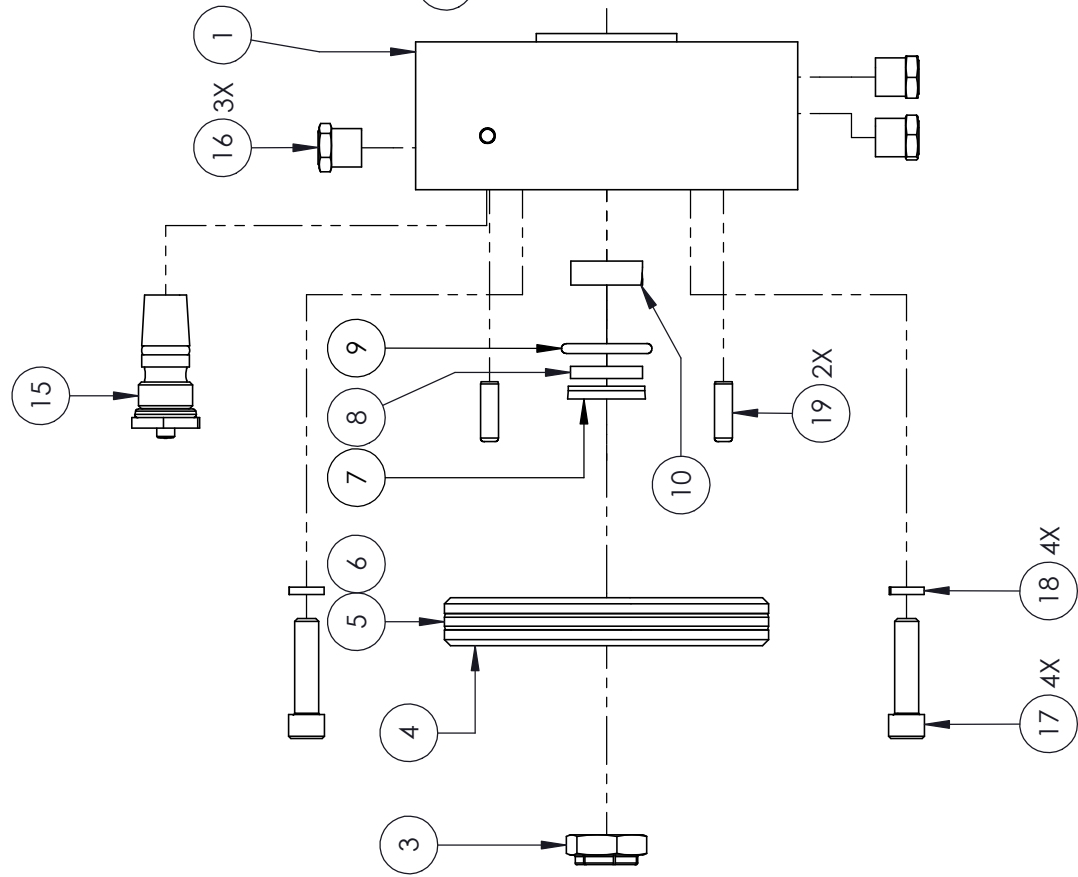

20	3	12043	FTG. PLUG, EXPANDER, 4MM
19	2	11772	PIN, DOWEL, .1875 DIA X .62 SS
18	4	10392	LOCKWASHER, HI COLLAR, 1/4
17	4	1/4-20 X 1 SHCS	SHCS
16	3	10264	BREATHER, 1/8 NPT
15	1	10017	ASSY, 2-W LIMIT VALVE
ITEM	QTY	PART NUMBER	DESCRIPTION

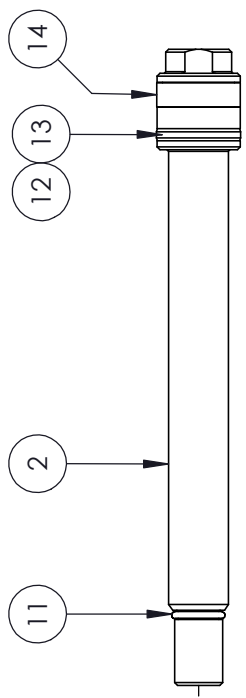

14	1	10647	SLYDE RING, .87X.75
13	1	SO-113B7	O-RING, BUNA
12	1	10373	GLYD RING, .875 OD
11	1	SO-905B7	O-RING, BUNA
10	1	10645	SLYDE RING, .75X.62
9	2	SO-116B7	O-RING, BUNA
8	2	10625	STEP SEAL, .625
7	2	11634	VARISEAL, 0.625 ID
6	1	SO-233B7	O-RING
5	1	10377	GLYD RING, 3.38 OD
4	1	10479	PISTON, -5 SAE
3	1	10439	FLEXLOC NUT, 1/2-20
2	1	13432	PISTON, HYDRAULIC, E030/30, MINI-MULE
1	1	13431	RATIO PLATE, E030/30, MINI-MULE
ITEM	QTY	PART NUMBER	DESCRIPTION

NOTES:
 1. APPLY WHITE LITHIUM GREASE TO ALL SEALS AND MOVING PARTS.

		INTERFACE DEVICES, INC. 230 DEPOT ROAD MILFORD, CT 06460	
SCALE: 1:2	TITLE: ASSEMBLY, RATIO	PLATE/PISTON, E030/30, BUNA SEALS	
DWN BY: NPI	REF: VARISEAL		
DATE: 8/11/2021	DWG NO: P12-1418		
SHT: 1 OF 1	REV: -		

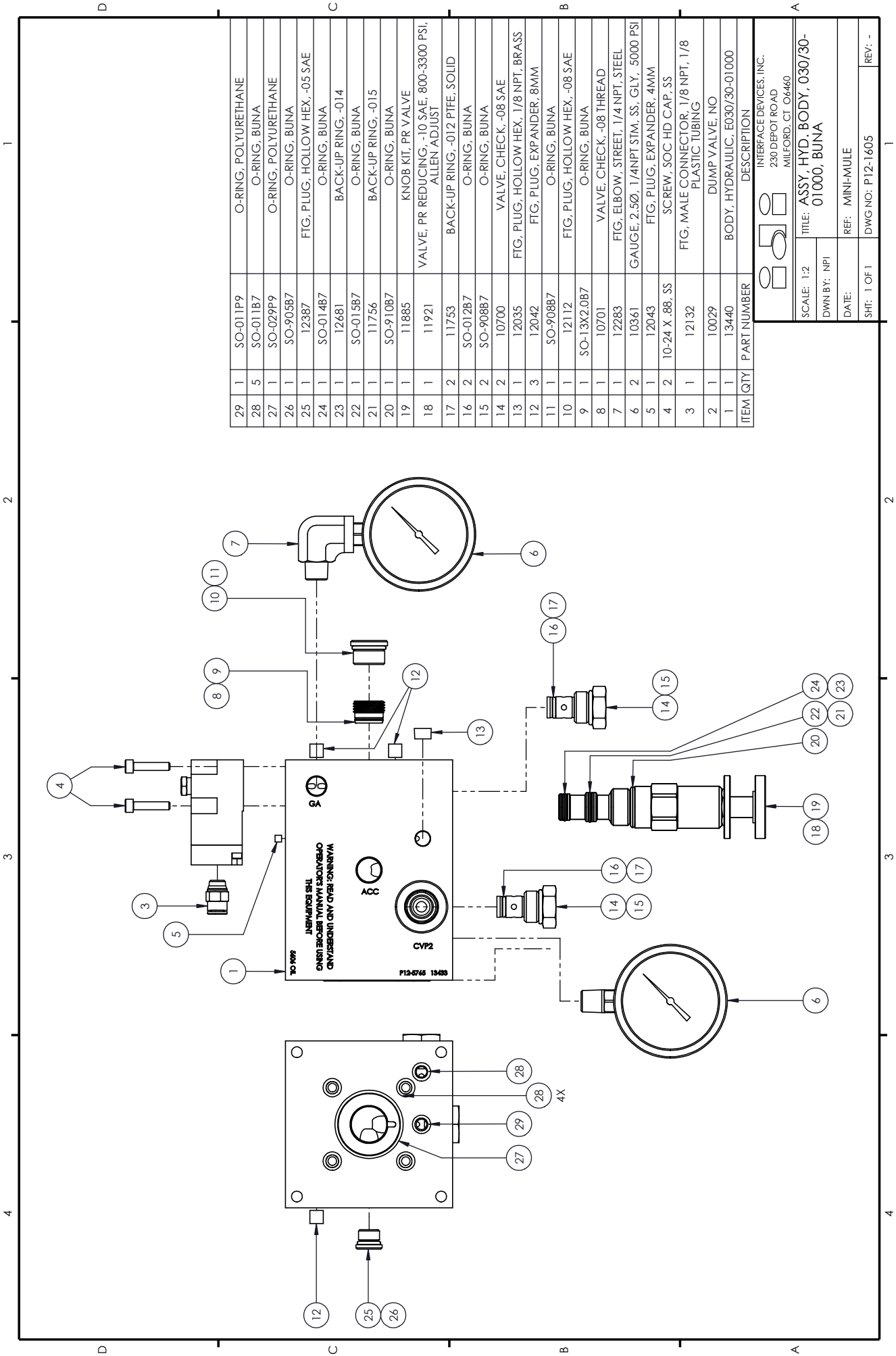

ITEM	QTY	PART NUMBER	DESCRIPTION
29	1	SO-011P9	O-RING, POLYURETHANE
28	5	SO-011B7	O-RING, BUNA
27	1	SO-029P9	O-RING, POLYURETHANE
26	1	SO-905B7	O-RING, BUNA
25	1	12387	FTG. PLUG, HOLLOW HEX, -.05 SAE
24	1	SO-014B7	O-RING, BUNA
23	1	12681	BACK-UP RING, -014
22	1	SO-015B7	O-RING, BUNA
21	1	SO-910B7	BACK-UP RING, -015
20	1	SO-910B7	O-RING, BUNA
19	1	11885	KNOB KIT, PR VALVE
18	1	11921	VALVE, PR REDUCING, -10 SAE, 800-3300 PSI, ALLEN ADJUST
17	2	11753	BACK-UP RING, -012 PTFE, SOLID
16	2	SO-012B7	O-RING, BUNA
15	2	SO-908B7	O-RING, BUNA
14	2	10700	VALVE, CHECK, -08 SAE
13	1	12035	FTG. PLUG, HOLLOW HEX, 1/8 NPT, BRASS
12	3	12042	FTG. PLUG, EXPANDER, 8MM
11	1	SO-908B7	O-RING, BUNA
10	1	12112	FTG. PLUG, HOLLOW HEX, -08 SAE
9	1	SO-13X2.0B7	O-RING, BUNA
8	1	10701	VALVE, CHECK, -08 THREAD
7	1	12283	FTG. ELBOW, STREET, 1/4 NPT, STEEL
6	2	10361	GAUGE, 2.5Ø, 1/4NPT STM, SS, GLY, 5000 PSI
5	1	12043	FTG. PLUG, EXPANDER, 4MM
4	2	10-24 X .88, SS	SCREW, SOC HD CAP, SS
3	1	12132	FTG. MALE CONNECTOR, 1/8 NPT, 1/8 PLASTIC TUBING
2	1	10029	DUMP VALVE, NO
1	1	13440	BODY, HYDRAULIC, E030/30-01000

INTERFACE DEVICES, INC. 230 DEPOT ROAD MILFORD, CT 06460	
SCALE: 1:2	TITLE: ASSY. HYD. BODY, 030/30-01000, BUNA
DWN BY: NPI	
DATE:	REF: MINI-MULE
SHT: 1 OF 1	DWG NO: P12-1605
	REV: -

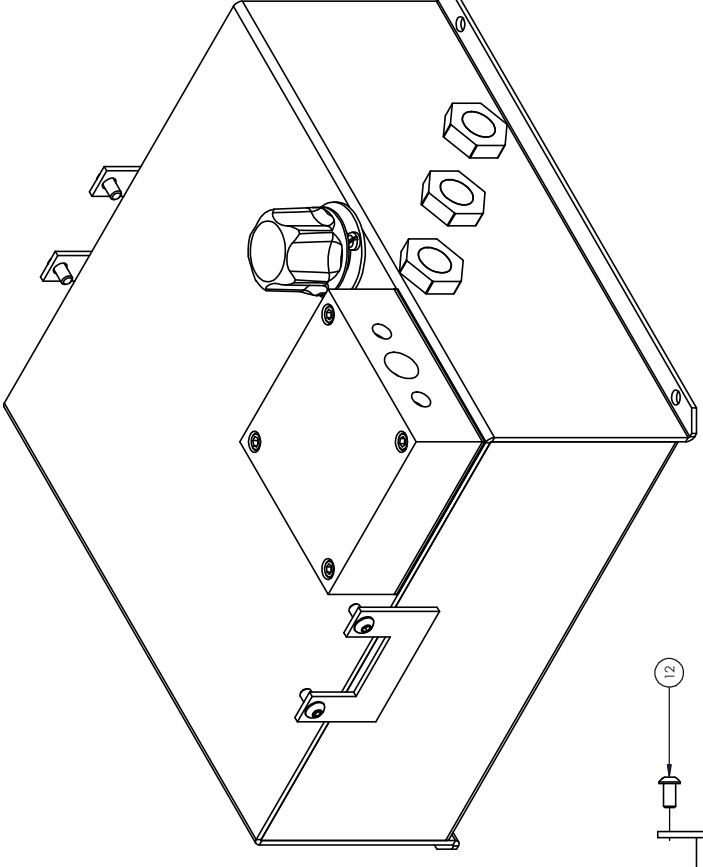
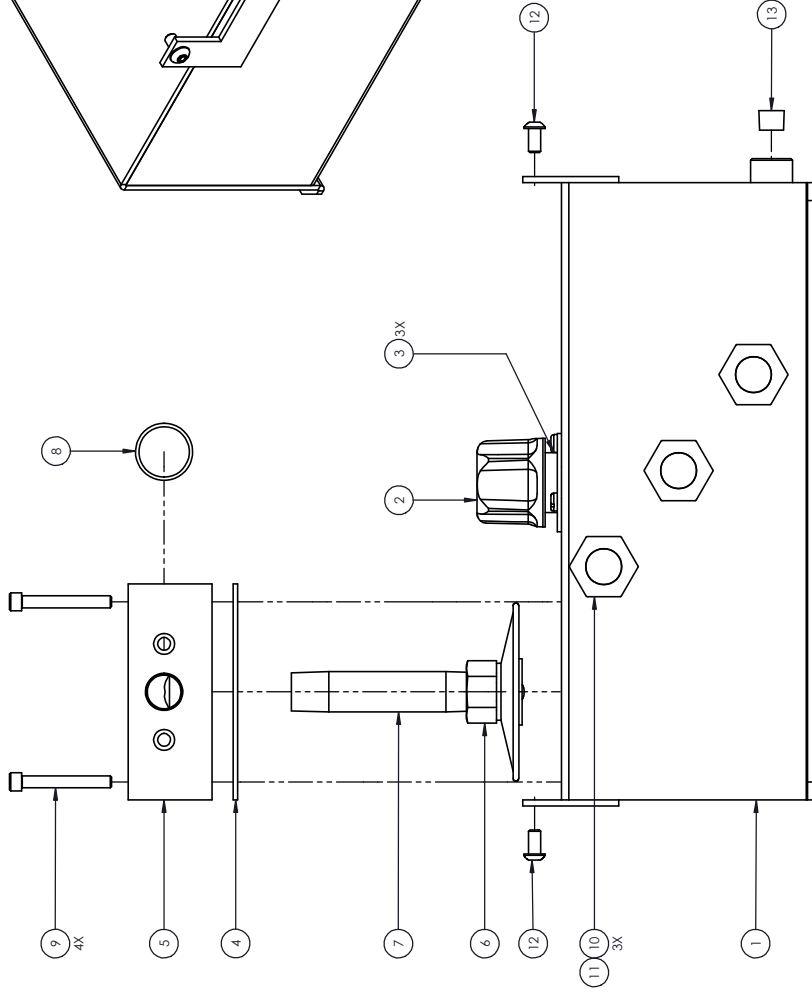

ITEM	QTY	PART NUMBER	DESCRIPTION
13	1	12095	FTG. PLUG, HOLLOW HEX, 1/4 NPT, BRASS
12	4	1/4-20 X .50, SS	SCREW, BTN HD CAP, SS
11	3	SO-912B7	O-RING, Buna
10	3	11.603	GAUGE, SIGHT, -12, STEEL/GLASS W/ REFLECTOR
9	4	1/4-20 X 1.88, SS	SCREW, SOC HD CAP, SS
8	1	SO-023B7	O-RING, Buna
7	1	12073	PIPE BRASS, 1/2 NPT X 4.00
6	1	10672	STRAINER, SUCTION, 1 STAGE, 100 MESH
5	1	13435	MANIFOLD, RESERVOIR
4	1	13436	GASKET, 3/32 Buna, 50A, ADHESIVE BACK
3	3	10-32 X .50, SS	SCREW, MACHINE, PAN HEAD, SS
2	1	10287	FILLER/BREATHER (W/STRAINER)
1	1	13434	RESERVOIR, ZGA.

INTERFACE SERVICES, INC.
 230 DEPOSIT ROAD,
 MIDDLED, CT 04460

SCALE: 1:2
 DWN BY: NPI
 DATE:
 REF:

TITLE: RESERVOIR ASSEMBLY,
 ZGA, MINI-MULE, Buna

PART NUMBER: 13428
 SHT: 1 OF 1
 DWG NO: P12-1901
 REV: -

PILOT CAP

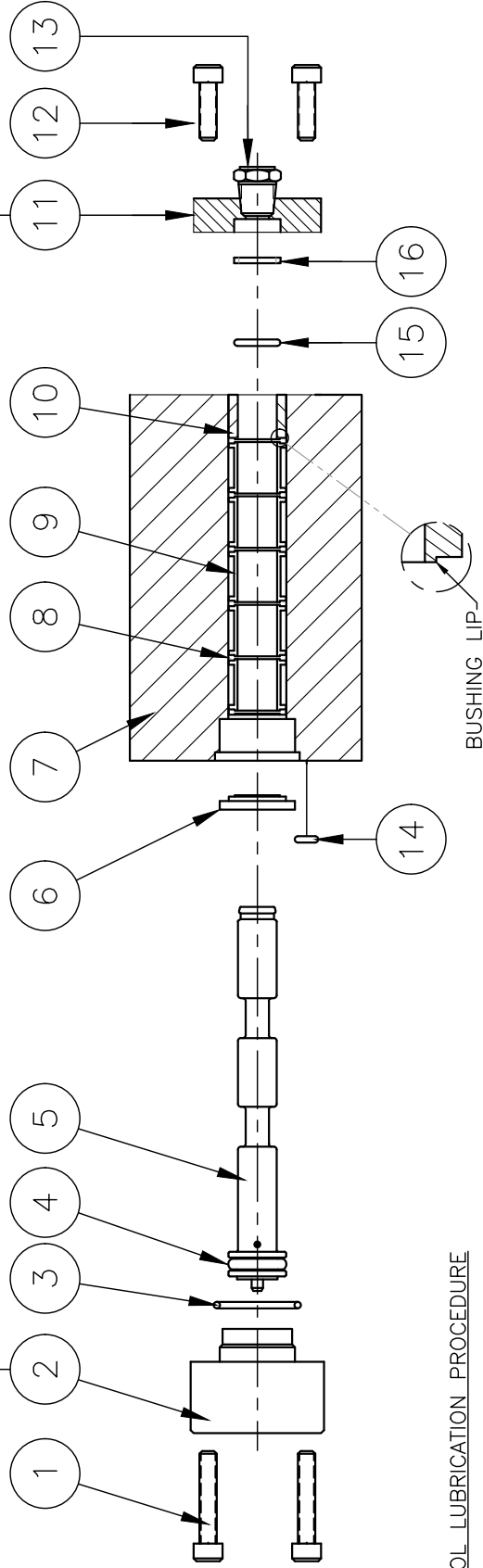

SPOOL LUBRICATION PROCEDURE

- 1 DISCONNECT AIR SUPPLY
- 2 LOOSEN AND REMOVE SCREWS AND SPOOL CAP (11,12)
- 3 LOOSEN AND REMOVE SCREWS, PILOT CAP AND O-RING (1-3,13,14)
- 5 EXTRACT SPOOL (5), BY PUSHING IT FROM THE SPOOL CAP END USING A BLUNT, SOFT SMALL DIAMETER TOOL.
- 6 CAREFULLY REMOVE THE BUSHINGS, CAGES AND TEE SEALS, (6,8,9,10) ONE AT A TIME. YOU MAY NEED A PICK TYPE TOOL MADE FROM A SOFT MATERIAL SUCH AS BRASS.
- 7 CLEAN ALL THE EXTRACTED PARTS WITH A SUITABLE PARTS CLEANSER
- 8 APPLY WATERPROOF GREASE TO O-RING AND BACKUP RING (15,16)
- 9 INSTALL O-RING AND BACKUP RING (15,16) INTO SPOOL CAP (11)
- 9 INSTALL THE SPOOL CAP (11, 12) DO NOT TIGHTEN - LEAVE APPROX .03" PLAY
- 10 APPLY "WHITE LITHIUM GREASE"* TO SEALS AND SPOOL (4,5,8)
- 11 REINSTALL THE LONG BUSHING (10) [NOTE ORIENTATION], TEE SEALS (8) & CAGES (9). INSTALL ONE PART AT A TIME, CAREFULLY SEATING EACH PART INDIVIDUALLY DO NOT REINSTALL THESE PARTS BY PLACING THEM ON THE SPOOL
- 10 INSTALL THE SHORT BUSHING (ITEM 6) AND CONFIRM IT IS SEATED
- 11 REINSTALL AIR SPOOL (5) PRESSING IT IN PLACE TO ALIGN THE SPOOL CAP AND SEALS
- 12 REINSTALL PILOT CAP (2), O-RING AND SCREWS (ITEMS 1-3)
- NOTE ORIENTATION OF PILOT CAP .09Ø HOLE TO O-RING (14)
- 10 RETIGHTEN SPOOL CAP SCREWS (ITEM 12)
- 11 RECONNECT AIR SUPPLY

16	1	11753	BU RING, SOLID, -012
15	1	SO-012P9	O-RING (POLY)
14	1	SO-006B7	O-RING
13	1	10264	BREATHER, 1/8 NPT
12	2	10-24 x .62	SOC HD CAP SCR
11	1	10299 P00-5208	SPOOL CAP
10	1	10269 P00-5210	LONG BUSHING
9	5	10273 P00-5209	CAGE
8	6	10629	TEE SEAL
7	REF		AIR CAP HSG
6	1	10271 P00-5212	SHORT BUSHING
5	1	10659 P00-5211	AIR SPOOL
4	1	SO-111B7	O-RING
3	1	SO-019B7	O-RING
2	1	11768 P00-1202	PILOT CAP ASSEMBLY
1	2	10-24 x 1	SOC HD CAP SCR
ITEM	QTY	PART NUMBER	DESCRIPTION

INTERFACE DEVICES, INC.
230 DEPOT ROAD
MILFORD, CT 06460

SCALE: HALF
DWN BY: WNI
DATE: 11/15/16
SHI: 1 OF: 1

TITLE: LUBRICATION INSTRUCTIONS,
UNBALANCED AIR SPOOL

REF: E, H & P SERIES PUMPS

DWG NO: P00-9023
REV: -

* RECOMMENDED GREASE:
WHITE LITHIUM GREASE WITH TEFLON

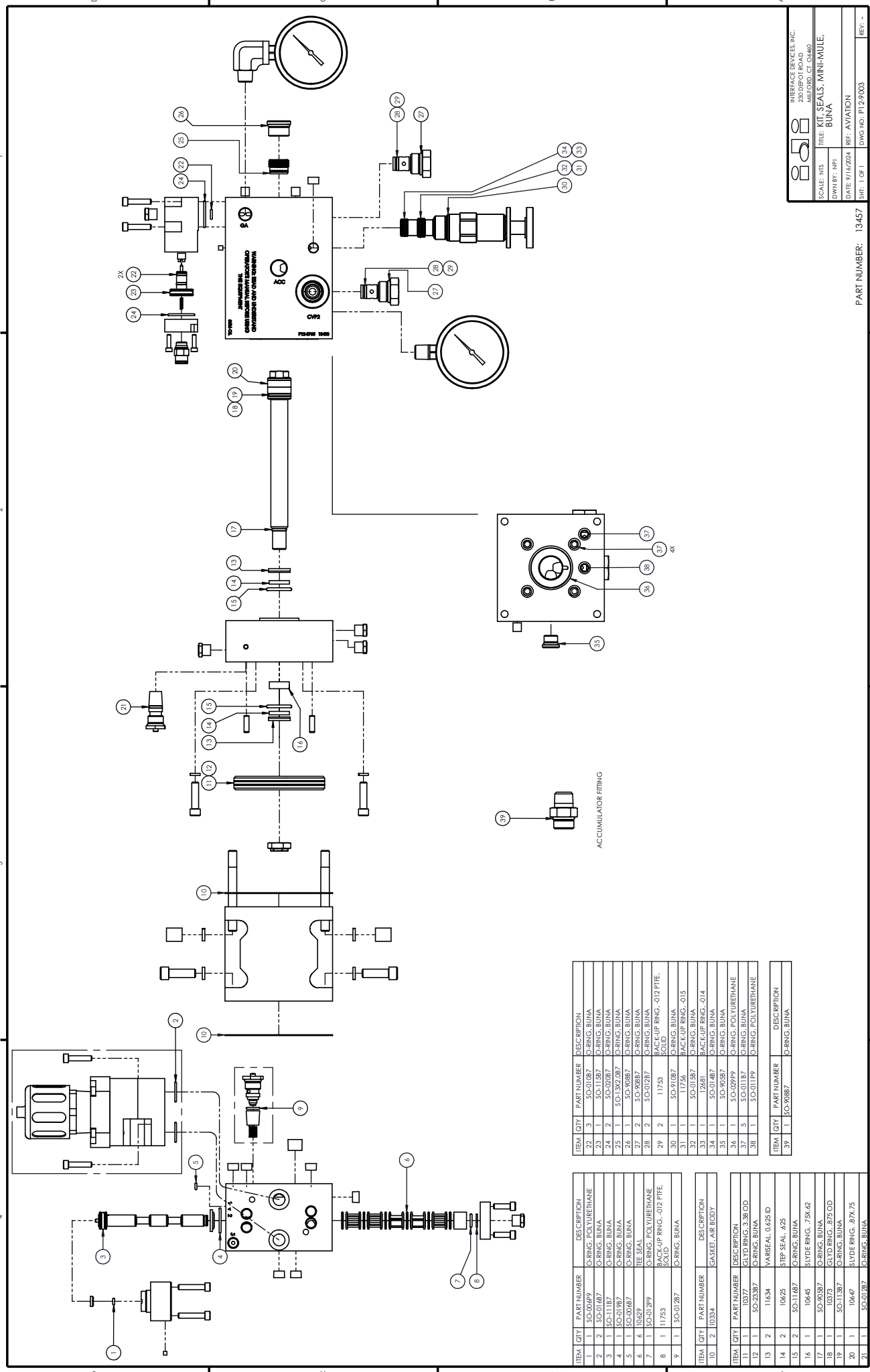

SCALE: NTS	TITLE: KIT, SEALS, MINI-MULE.
DRAWN BY: NPI	BUNA
DATE: 9/16/2024	REF: AVIATION
SHEET: 1 OF 1	DWG NO: P12-9003

PART NUMBER: 13457

ITEM	QTY	PART NUMBER	DESCRIPTION
22	3	SO-01187	O-RING, BUINA
23	1	SO-01187	O-RING, BUINA
24	2	SO-02087	O-RING, BUINA
25	1	SO-1302,087	O-RING, BUINA
26	1	SO-90887	O-RING, BUINA
27	2	SO-90887	O-RING, BUINA
28	2	SO-01287	O-RING, BUINA
29	2	11753	BACK-UP RING, -012 PITE, SOLID
30	1	SO-91087	O-RING, BUINA
31	1	11756	BACK-UP RING, -015
32	1	SO-01587	O-RING, BUINA
33	1	12681	BACK-UP RING, -014
34	1	SO-01487	O-RING, BUINA
35	1	SO-90587	O-RING, BUINA
36	1	SO-02919	O-RING, POLYURETHANE
37	5	SO-01187	O-RING, BUINA
38	1	SO-01119	O-RING, POLYURETHANE

ITEM	QTY	PART NUMBER	DESCRIPTION
1	1	SO-0879	O-RING, POLYURETHANE
2	2	SO-1187	O-RING, BUINA
3	1	SO-01187	O-RING, BUINA
4	1	SO-01187	O-RING, BUINA
5	1	SO-00487	O-RING, BUINA
6	6	10429	TEE SEAL
7	1	SO-01299	O-RING, POLYURETHANE
8	1	11753	BACK-UP RING, -012 PITE, SOLID
9	1	SO-01287	O-RING, BUINA

ITEM	QTY	PART NUMBER	DESCRIPTION
39	1	SO-90887	O-RING, BUINA

ITEM	QTY	PART NUMBER	DESCRIPTION
10	2	10334	GASKET, AIR BODY

ITEM	QTY	PART NUMBER	DESCRIPTION
11	1	10377	GLYD RING, 3.38 OD
12	1	SO-22387	O-RING, BUINA
13	2	11634	VARIABLE, 0.625 ID

ITEM	QTY	PART NUMBER	DESCRIPTION
14	2	10625	STEP SEAL, .625
15	2	SO-11687	O-RING, BUINA
16	1	10645	GLYD RING, .75X.62
17	1	SO-90587	O-RING, BUINA
18	1	10273	GLYD RING, .875 OD
19	1	SO-11387	O-RING, BUINA
20	1	10647	GLYD RING, .87X.75
21	1	SO-01287	O-RING, BUINA

ACCUMULATOR FITTING

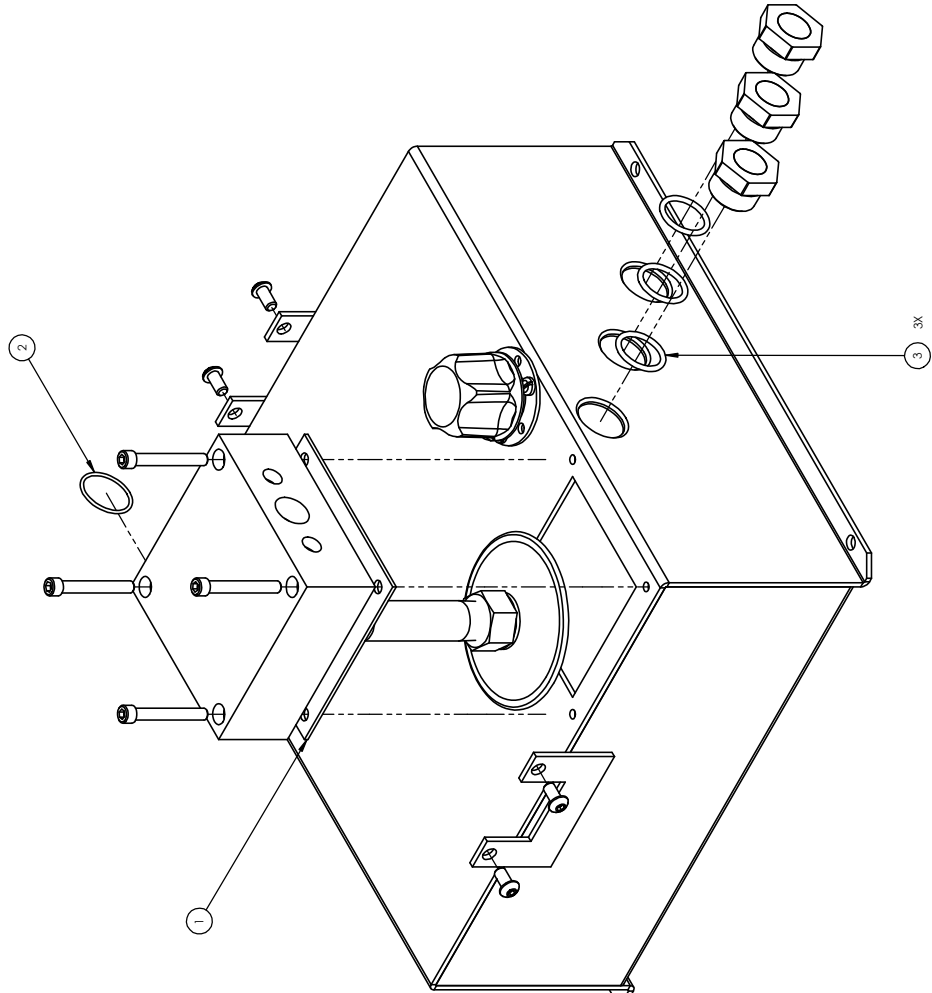

3	3	SO-912B7	O-RING, BUNA
2	1	SO-023B7	O-RING, BUNA
1	1	13436	CASSET, 3/32 BUNA, 50A, ADHESIVEBACK
ITEM	QTY	PART NUMBER	DESCRIPTION
INTERFACE SERVICES, INC. 230 DEBOUT ROAD, MILFORD, CT 06460			
SCALE: 1:2		TITLE: KIT, SEALS, MINIMULE, RESERVOIR, BUNA	
DWN BY: NPI		REF:	
DATE: 9/16/2024		DWG NO: P12-9005	
SHT: 1 OF 1		REV: -	

PART NUMBER: 13459