

REV	DESCRIPTION	DATE
A	ADDED AIR IN RELIEF VALVE	1/10/03
B	DWG WAS GA9901182 A; PICTURE CHANGE MUFFLER 9.9 WAS 10.9	3/25/03
C	PICTURE CHANGE: NEW SC REGULATOR	3/23/05
D	ADDED MTG BRACKET & DIMS	3/15/12
E	ADDED SHEET 2	9/10/13
F	PICTURE CHANGE: REGULATOR KNOB	9/17/19

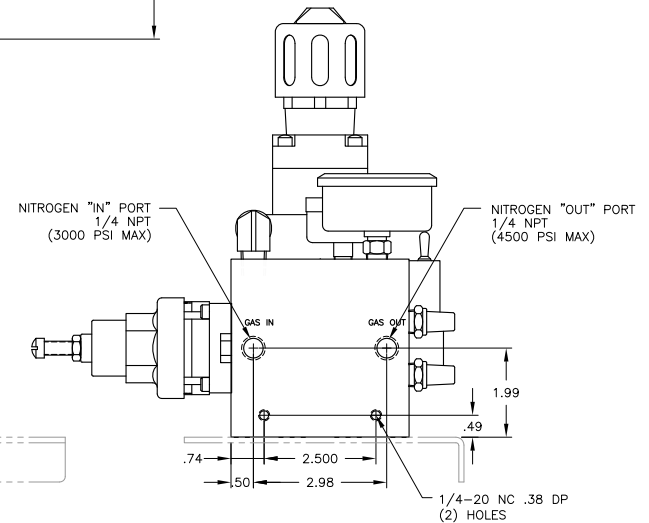

NOTES

- SOME COMPONENTS NOT SHOWN IN ALL VIEWS FOR CLARITY
- TO RUN PUMP ON SHOP AIR, CONNECT QUICK DISCONNECT TO AIR SUPPLY TO RUN PUMP FROM NITROGEN CYLINDER, CONNECT QUICK DISCONNECT TO FEMALE DISCONNECT ON PUMP

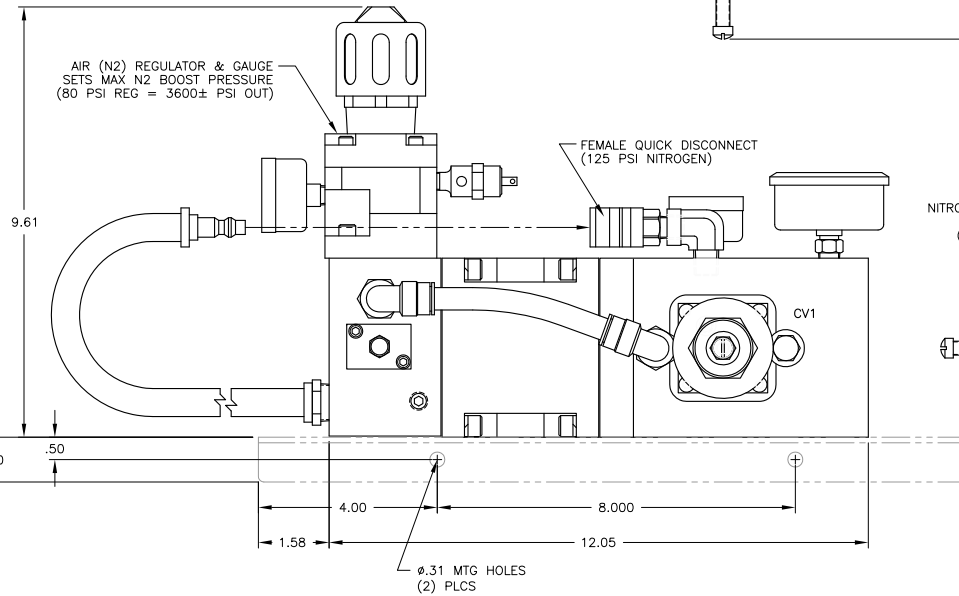
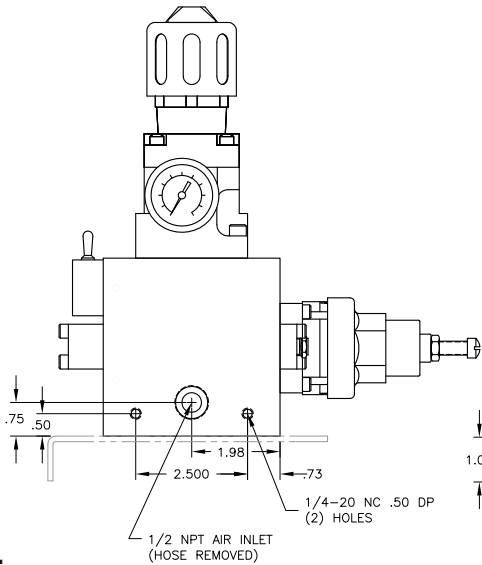
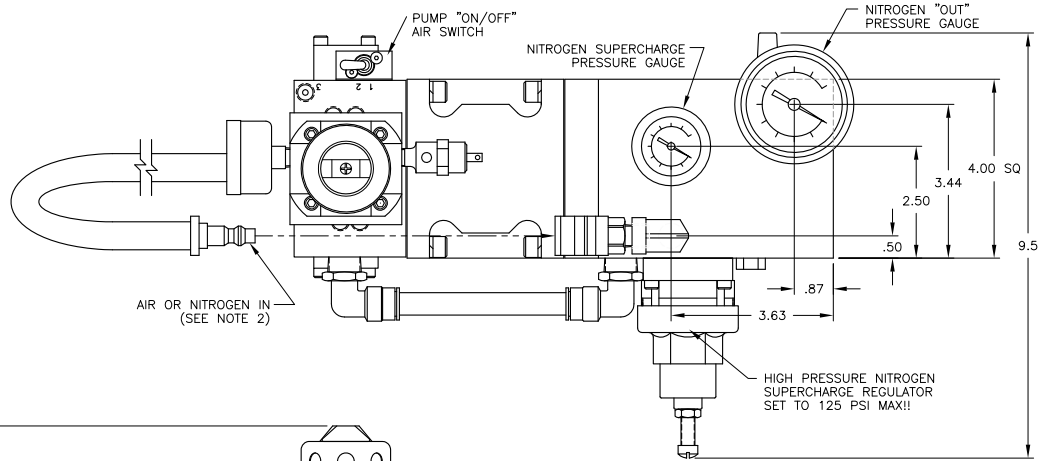
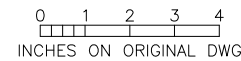

		INTERFACE DEVICES, INC. 230 DEPOT ROAD MILFORD, CT 06460	
SCALE: NONE	TITLE: GENERAL ARRANGEMENT, NB-45 BOOSTER (AVIATION)		
DWN BY: WNI	DATE: 1/18/99 REF: (DIRECT CONNECT TO HP CYL)		
SH: 1 OF: 2	DWG NO: P32-0001	REV: F	

REV	DESCRIPTION	DATE
A	ADDED AIR IN RELIEF VALVE	1/10/03
B	DWG WAS GA9901182 A; PICTURE CHANGE MUFFLER 9.9 WAS 10.9	3/25/03
C	PICTURE CHANGE: NEW SC REGULATOR	3/23/05
D	ADDED MTG BRACKET & DIMS	3/15/12
E	ADDED SHEET 2	9/10/13
F	PICTURE CHANGE: REGULATOR KNOB	9/17/19

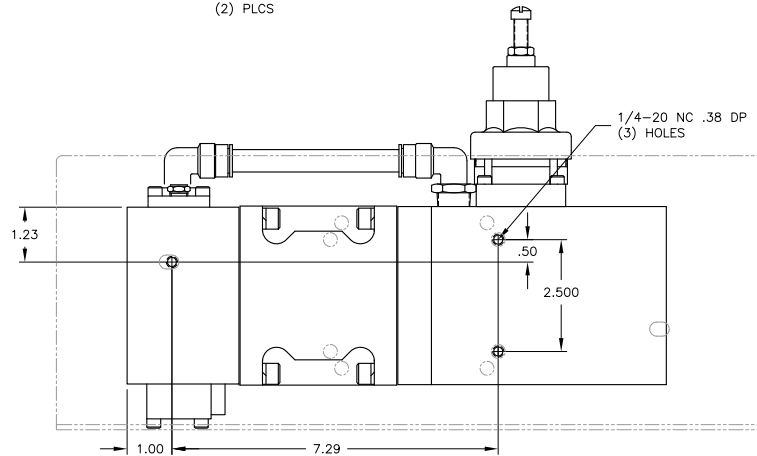
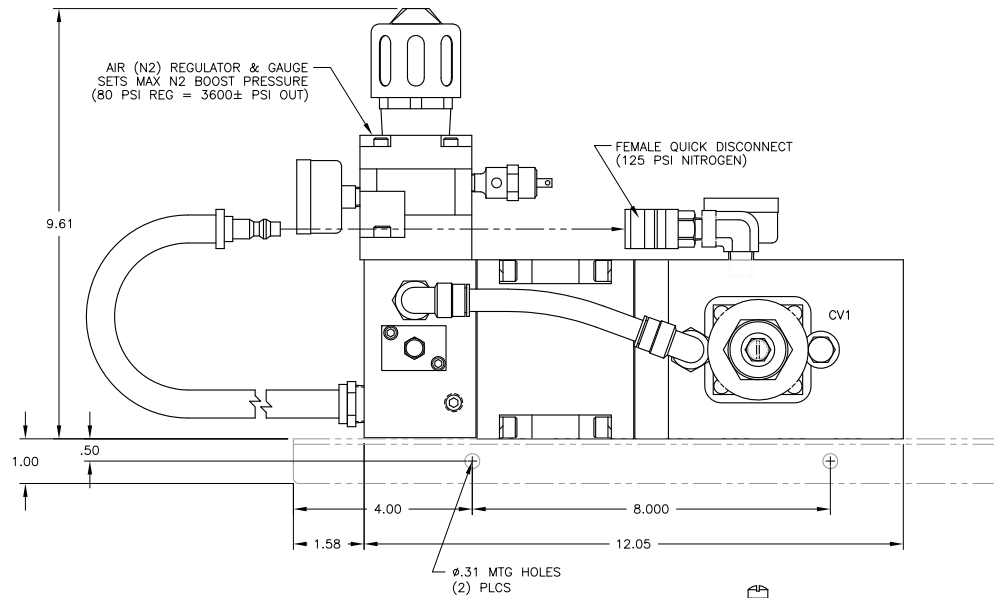

NOTES

- SOME COMPONENTS NOT SHOWN IN ALL VIEWS FOR CLARITY
- TO RUN PUMP ON SHOP AIR, CONNECT QUICK DISCONNECT TO AIR SUPPLY  
TO RUN PUMP FROM NITROGEN CYLINDER, CONNECT QUICK DISCONNECT TO FEMALE DISCONNECT ON PUMP

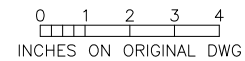

		INTERFACE DEVICES, INC. 230 DEPOT ROAD MILFORD, CT 06460
SCALE: NONE	TITLE: GENERAL ARRANGEMENT, NB-45 BOOSTER (AVIATION)	
DWN BY: WNI	DATE: 1/18/99 REF: (DIRECT CONNECT TO HP CYL)	
SH: 2 OF: 2	DWG NO: P32-0001	REV: F